

# THE DESLUGGER

## INSTRUCTION SHEET

36140 / 208786 / A08786

### THE DESLUGGER

**Note: Kit contains 4 male and 4 female bullet connectors and 1 eyelet for installation.**

Polarity must match up

- Red Positive and White Ground = Input
- Red Positive and Black Ground = Output

1. Remove output side of heat switch and add bullet connector. Connect to red input side of Deslugger.
2. Remove coil ground lead screw then remove eyelet. Add bullet connector and then connect to ground side of coil. Then connect to black output side of Deslugger. Use bullet connectors.
3. Add bullet connector to positive side of coil lead and then use bullet connector to red output side of Deslugger.
4. Add eyelet to white input side of Deslugger and screw back down where it was taken off. (See #2)
5. Zip tie or mount Deslugger to stationary part.

The Deslugger will cycle multiple times and then fully engage when power is applied.

During a normal cycle on a cooler day when the suction pressure gets too low or when there is a high pressure cycle, The Deslugger will recognize it as a normal condition and not repeat the cycle sequence again.

Any time the compressor is in the off position for more than 30 minutes, The Deslugger will reset and the process will repeat from the start.

The Deslugger will not repeat the cycle at any time when the power has been removed for less than 30 minutes.

Note: The Deslugger functions by pulsating clutch ground circuit during initial compressor engagement.

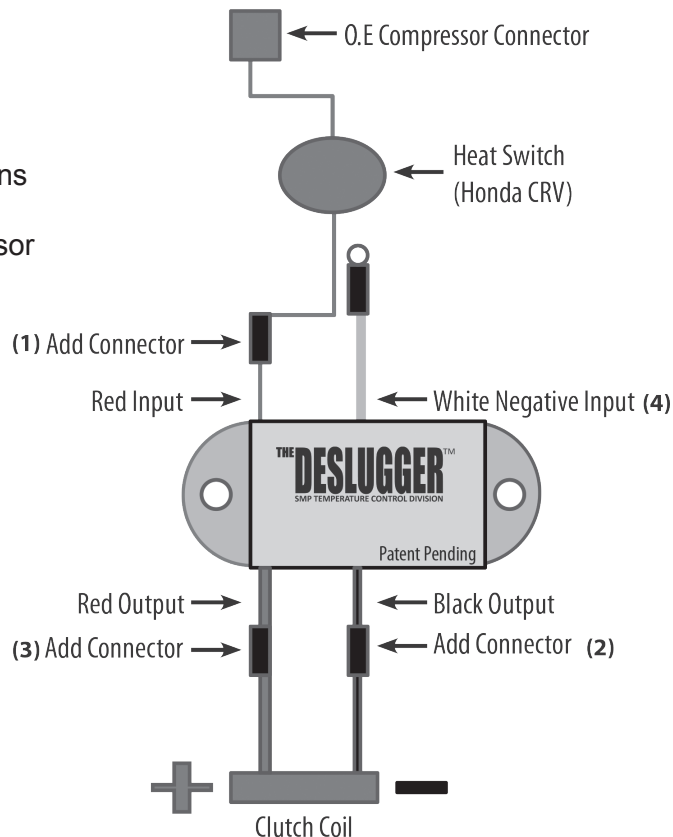

Wiring Diagram